

0111110000111 SAFETY 0000111100011110101010000111100000011111000011100
001111000000111110000111 RELIABILITY 0000111100011110101010000111100000
1000111101010100001111000000 1110000111 EFFICIENCY 0000111100011110101
00000111110000111 COMPLIANCE 01111000111101010100001111000000111110
10101010000111100000011110 PERFORMANCE 000011110001111010101000



HydroGuard[®] XP

**The Next Wave in Emergency
Tempering Valve Technology**

1 SAFETY 000011
0111110000111 R
101000011110000
00111 COMPLIANC
11100000011111

■ ASSE 1071 Listed 

■ Internal Cold Water Bypass - Patent Pending

■ Eye and Face Washes, Drench Showers,
Combination Units

POWERS[™]

Water Tempering Innovation Since 1891





A History of Tempering Valve Innovation and Leadership It's in our DNA

Since 1891, Powers continues to prove itself the leader in specified water tempering control devices for commercial, industrial and institutional facilities. Year after year, decade after decade, Powers improves its products through the evolution of its technologies, the innovation of its designs and the commitment of its employees.

Today, Powers introduces HydroGuard® XP, the next wave of ASSE 1071 listed valves with more features, a simplified design and greater bypass flows. Four new and completely re-engineered valves meet a broad range of capacity requirements and applications. When considering your next specification, consider the company whose DNA is tempering.



Eye/Face Wash

Drench Shower

ASSE 1071 Listed!

Powers' HydroGuard XP series valves meet the stringent performance requirements of ASSE 1071, "Temperature Actuated Mixing Valves for Plumbed Emergency Equipment". The XP series carries the coveted ASSE seal. They are designed to deliver tepid (lukewarm) water to eye/face wash, drench shower and combination fixtures.

Important Requirements of ASSE 1071 Include:

1. Intended to be installed with fixtures that comply with ANSI Z358.1-2004.
2. Valves must have an adjustable outlet temperature range, with a portion that falls within 65.0°F to 95.0°F (18.3°C to 35.0°C). The outlet temperature cannot exceed 100.0°F under normal operating conditions (Section 1.2.4.2).
3. Upon hot water failure, valves must continue to provide cold-water flow at the manufacturers rated bypass flow, at a 30psi differential (Section 1.2.5).
4. Upon cold-water failure, valves must restrict hot water flow per Table 1 (Section 1.2.6). Flow varies by valve capacity.
5. The temperature control test requires valves to maintain temperature within a specified variation based on capacity. First, flow is recorded at a 30 psid differential, then reduced to 3 gpm or manufacturer's minimum stated flow, whichever is lower. Valve is restored back to full flow and hot water temperature is increased by 25°F over 5 minutes. Flow is again reduced to 3 gpm.



ASSE 1071 - Temperature Control and Cold Water Failure Limits					
Flow at 30 psid		Permissible Temperature Variation		Max. Allowable Flow with CW Shutoff	
GPM	L/min	°F	°C	GPM	L/min
< 7.0	< 26.5	+ 3.0 / -5.0	+ 1.7 / -2.8	0.5	1.9
7.0 < 20.0	26.5 < 75.7	+ 5.0 / -8.0	+ 2.8 / -4.4	1.0	3.8
20.0 < 40.0	75.7 < 151.4	+ 7.0 / -12.0	+ 3.9 / -6.7	1.5	5.7
40.0 and over	151.4 and over	+ 7.0 / -15.0	+ 3.9 / -8.3	2.0	7.6

Engineered with Performance and Safety in Mind

- 1 Lockable, vandal-resistant temperature adjustment with high temperature limit stop is factory set at 85°F
- 2 Advanced paraffin actuation technology responds quickly to changes in water temperature
- 3 Booster funnel channels water directly around paraffin actuator to improve response time and provide greater low flow control
- 4 Patented internal bypass allows cold-water flow in the event of hot water failure
- 5 Corrosion resistant internals resist seizing or sticking in harsh water conditions, ensuring safe and consistent valve performance after extended periods of down time
- 6 Triple-duty check stops prevent cross flow, provide valve isolation for repair and include screens to filter out debris.

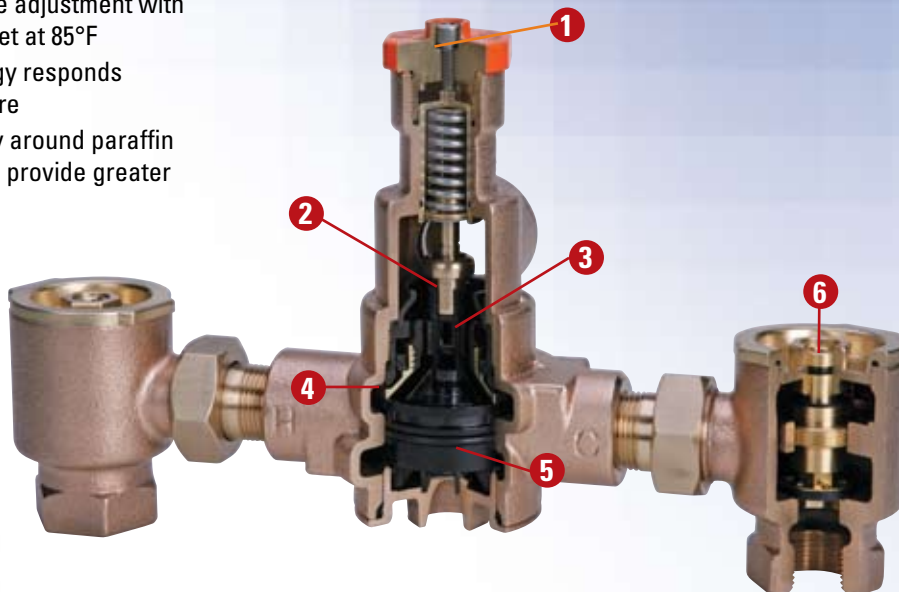

Cold Water Bypass

Unlike standard master tempering valves, Powers' new Emergency Valve series provides substantial cold-water flow in the event of hot water supply loss. This is accomplished through a unique and patented internal bypass channel and check valve.

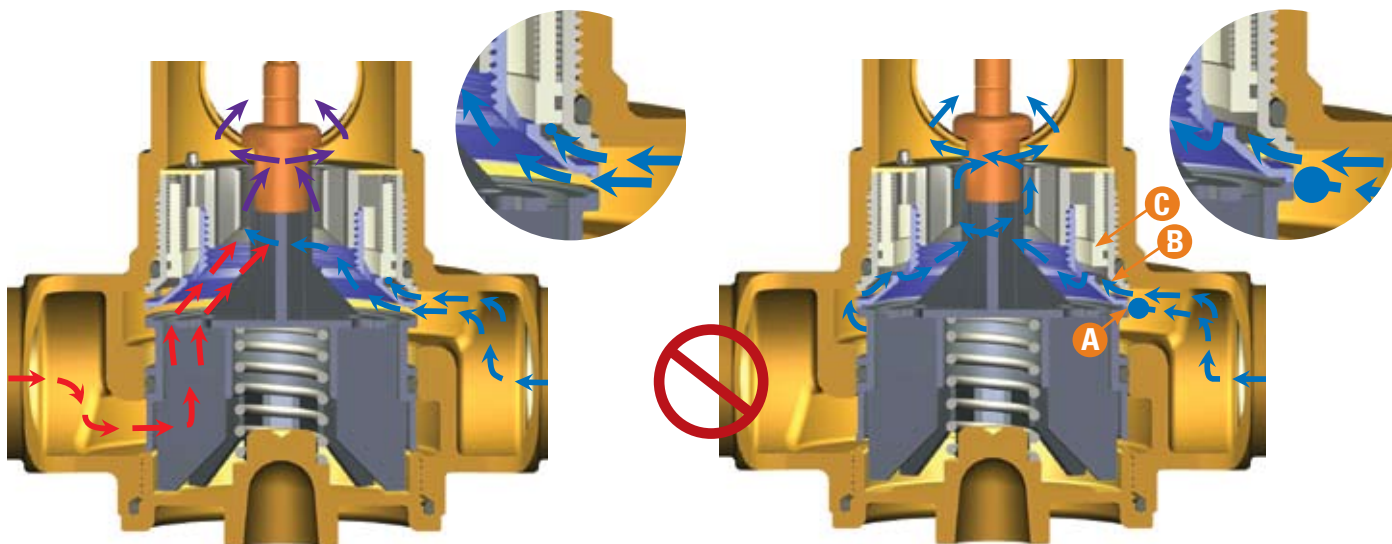

Normal Operation – Blended, Controlled Outlet Temperature Cold Water Bypass Closed

Hot and cold water enter internal chamber through seating areas, are blended together, and directed around actuator to the outlet. Paraffin actuator expands and contracts based on outlet water temperature.

Hot Water Supply Loss – Cold Water Bypass Opens

Loss of hot water causes paraffin actuator to contract. Lower spring pushes mixing assembly upwards and closes off cold water supply at **Seating Area A**. With closing of Seating Area A, pressure builds in Bypass **Channel B**, pushing **Check Assembly C** off of seat and allows cold water to flow through to the outlet.

The Heart of HydroGuard® XP

At the core is Powers' paraffin-based Advanced Thermal Actuation technology that operates on the principle of converting heat energy into mechanical energy, using the expansion of paraffin from a solid to a liquid state. As shown in this illustration, when the temperature of the water enveloping the sensor increases, the expansion of the paraffin actuates the valve piston. As the water cools, the paraffin contracts into a solid and the valve piston returns to its starting position.

Powers' paraffin sensor is significantly smaller in size than bi-metal and chemical filled elements and requires only a small volume of water to initiate thermal transfer and response.

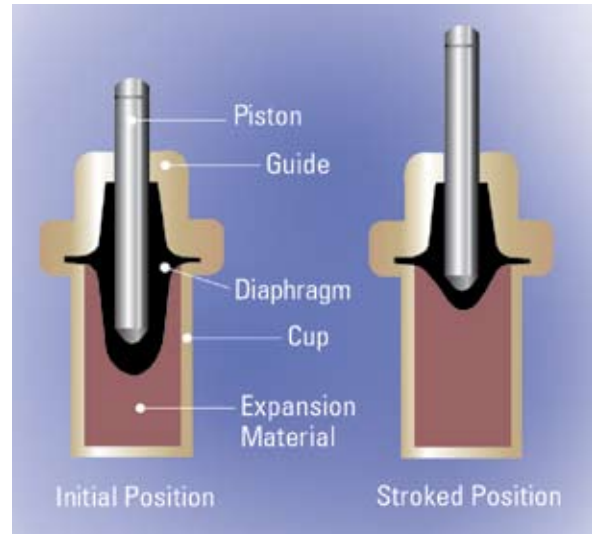

Product Specification

Maximum Operating Pressure 125psi (861 kPa)
 Maximum Hot Water Temperature 180°F (82°C)
 Temperature Adjustment Range 60 – 95°F (15 – 35°C)
 Factory Set Temperature* 85°F (29°C)
 Maximum Flow with Cold Water Shutoff* 0.5 gpm (1.9 lpm)

Listing...ASSE 1071



*When tested to ASSE 1017 standard

Capacity

Model	Min Flow to ASSE 1071	C _v	CW Bypass @ 30psi	Pressure					
				5psi 34 kPa	10psi 69 kPa	15psi 103 kPa	20psi 138 kPa	30psi 207 kPa	45psi 310 kPa
ES150	1.0 gpm 3.8 lpm	1.59	6.5 gpm 25 lpm	3.6 gpm 13.6 lpm	5.0 gpm 18.9 lpm	6.2 gpm 23.5 lpm	7.1 gpm 26.9 lpm	8.7 gpm 32.9 lpm	10.7 gpm 40.5 lpm
ETV200	3.0 gpm 11.4 lpm	6.0	30 gpm 114 lpm	13.4 gpm 50.7 lpm	19.0 gpm 71.9 lpm	23.2 gpm 87.8 lpm	26.8 gpm 101.4 lpm	32.9 gpm 124.5 lpm	40.2 gpm 152.2 lpm
ETV400	3.0 gpm 11.4 lpm	15.2	50 gpm 189 lpm	34.0 gpm 128.7 lpm	48.1 gpm 182.0 lpm	58.9 gpm 223.0 lpm	68.0 gpm 257.4 lpm	83.2 gpm 315.0 lpm	102.0 gpm 386.1 lpm
ETV500	3.0 gpm 11.4 lpm	21.8	81 gpm 307 lpm	48.7 gpm 184.3 lpm	68.9 gpm 260.8 lpm	84.4 gpm 319.5 lpm	97.5 gpm 369.1 lpm	119.4 gpm 452.0 lpm	146.2 gpm 553.4 lpm

Flow capacity at 85°F (29°C)

POWERS™

A Watts Water Technologies Company

**ISO 9001-2000
CERTIFIED**

USA: Phone: 1.800.669.5430 • Fax 1.847.229.0526 • www.powerscontrols.com
 Canada: Phone: 1.888.208.8927 • Fax 1.888.479.2887 • www.powerscontrols.ca