

**Product Specification**

**Features ■**

- Valve utilizes paraffin-based advanced thermal actuation technology to sense and adjust outlet temperature
- Dirt and lime resistant poppet and seat design
- Virtual shutoff if supply pressure fails
- Vandal-resistant locking mechanism to secure temperature setting
- Factory tested
- Rotatable union triple-duty checkstops
- Rough bronze and chrome finishes

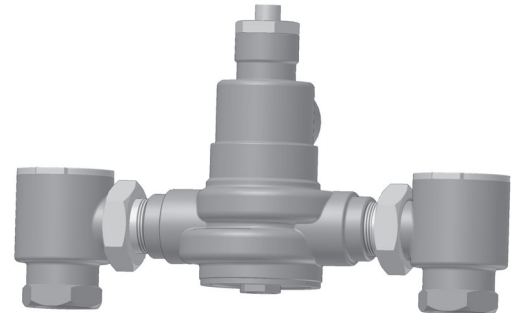

Advanced Thermal Activation

**Specifications ■**

- Connections . . . . . See chart on reverse
- Maximum Hot Water Supply Temperature . . . 200°F (93°C)
- Minimum Hot Water Supply Temperature . . . 5°F (3°C) above set point\*
- Minimum Flow\*\* . . . . . 0.5 gpm (1.9 lpm)
- Maximum Operating Pressure . . . . . 125 psid (861 kPa)
- Temperature Adjustment Range . . . . . Standard 90 – 160°F (32 – 71°C)  
Low 60 – 90°F (16 – 32°C)
- Hot Water Inlet Temperature Range . . . . . 120 – 180°F (49 – 82°C)
- Cold Water Inlet Temperature Range . . . . . 40 – 80°F (4 – 27°C)
- Listing/Compliance . . . . . ASSE 1017, CSA B125

\* With equal pressure

\*\* Minimum flow when the valve is installed at or near hot water source w/re-circulated tempered water with a properly sized continuously operating re-circulating pump

**Capacity ■**

Flow Capacity at 50-50 mixed ratio									
Model	Min. Flow to ASSE 1017	Pressure Drop Across Valve							
		Cv	5psi (34 kPa)	10psi (69 kPa)	20psi (69 kPa)	30psi (207 kPa)	45psi (310 kPa)	60psi (414 kPa)	70psi (517 kPa)
MM431	3 gpm 11 lpm	6.32	14 gpm 53 lpm	20 gpm 76 lpm	28 gpm 106 lpm	35 gpm 132 lpm	42 gpm 159 lpm	49 gpm 185 lpm	53 gpm 201 lpm
MM432	4 gpm 15 lpm	9.49	21 gpm 80 lpm	30 gpm 114 lpm	42 gpm 159 lpm	52 gpm 197 lpm	64 gpm 242 lpm	74 gpm 280 lpm	79 gpm 299 lpm
MM433	5 gpm 19 lpm	16.44	37 gpm 140 lpm	52 gpm 197 lpm	74 gpm 280 lpm	90 gpm 341 lpm	110 gpm 416 lpm	127 gpm 481 lpm	138 gpm 522 lpm
MM434	7 gpm 26 lpm	21.50	48 gpm 182 lpm	68 gpm 257 lpm	96 gpm 363 lpm	118 gpm 447 lpm	144 gpm 545 lpm	167 gpm 632 lpm	180 gpm 681 lpm
MM435	10 gpm 38 lpm	31.00	69 gpm 261 lpm	98 gpm 371 lpm	139 gpm 526 lpm	170 gpm 644 lpm	208 gpm 787 lpm	240 gpm 908 lpm	259 gpm 980 lpm

## Dimensions ■

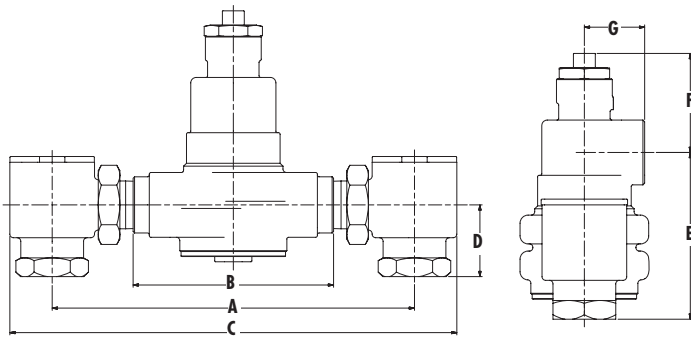

Valve	A	B	C	D	E	F	G
MM431	9-1/8"	4-3/4"	11-3/8"	1-7/8"	4"	3-1/4"	1-5/8"
	(232)	(121)	(289)	(48)	(102)	(83)	(41)
MM432	9-1/8"	4-3/4"	11-3/8"	1-7/8"	4"	3-1/4"	1-5/8"
	(232)	(121)	(289)	(48)	(102)	(83)	(41)
MM433	12-5/8"	7"	15-1/2"	2-1/2"	5-3/4"	3-1/2"	2-1/16"
	(321)	(178)	(394)	(64)	(146)	(89)	(52)
MM434	12-5/8"	7"	15-1/2"	2-1/2"	5-3/4"	3-1/2"	2-1/16"
	(321)	(178)	(394)	(64)	(146)	(89)	(52)
MM435	15-5/8"	7-1/8"	19-1/4"	2-3/4"	7-7/8"	4-3/8"	2-3/8"
	(397)	(181)	(489)	(70)	(200)	(111)	(60)

Valve	Inlets NPT	Outlet NPT
MM431	3/4"	3/4"
MM432	3/4"	1"
MM433	1-1/4"	1-1/4"
MM434	1-1/4"	1-1/2"
MM435	2"	2"

Note:  
 Dimensions are shown  $\pm 1/4"$   
 Dimensions in brackets are in mm

## Ordering Information ■



Valve	Order Code
42 gpm (159 lpm)	MM431
64 gpm (242 lpm)	MM432
110 gpm (416 lpm)	MM433
144 gpm (545 lpm)	MM434
208 gpm (787 lpm)	MM435

### Finish/ Temperature Range

Rough Bronze, Standard (90 - 160°F)	1
Chrome Plated, Standard (90 - 160°F)	2
Rough Bronze, Low (60 - 90°F)	3
Chrome Plated, Low (60 - 90°F)	4

## Recirculation Piping Diagram

Please see Piping Diagram Section of this catalog.

## Typical Specification ■

Master mixing valve shall feature paraffin-based, thermal actuation technology for precise temperature control. Valve shall be listed to ASSE 1017 and CSA B125 and have an approach temperature of 5°F. Valve shall have an outlet temperature range from 90 – 160°F with a lockable temperature-setting feature. Valve shall be manufactured of corrosion resistant materials and feature a single-seat design for positive shutoff. Valves shall come standard with union check stops. Minimum flows to ASSE 1017 shall be MM431 (3.0 gpm), MM432 (4.0 gpm), MM433 (5.0 gpm), MM434 (7.0 gpm), MM435 (10.0 gpm).

Master mixing valves shall be of Powers series MM430. Any alternate must have a written approval prior to bidding.

### ENGINEERING APPROVAL

Project: \_\_\_\_\_  
 Contractor: \_\_\_\_\_  
 Architect/Engineer: \_\_\_\_\_

# POWERS™

a division of Watts Water Technologies, Inc.

**ISO 9001**  
 CERTIFIED

USA: Phone: 1.800.669.5430 • Fax 1.847.229.0526 • www.powerscontrols.com  
 Canada: Phone: 1.888.208.8927 • Fax 1.888.882.1979 • www.powerscontrols.ca