

Product Specification

Features ■

- Powers' Advanced Thermal Actuator provides precise temperature control
- Exclusive internal cold water bypass ensures cold water flow in the event of loss of hot water
- Flow effectively shuts down upon loss of cold water supply when tested under the condition specified in ASSE 1071 standard
- Vandal-resistant locking mechanism to secure temperature setting
- Factory tested
- Rough bronze and chrome finishes
- Checkstops to prevent cross flow

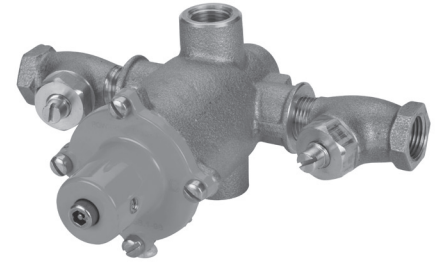

Advanced Thermal Activation

US Patent 6,575,377

Specifications ■

- Connections 1/2" (15mm) NPT inlets and outlet
- Maximum Operating Pressure 125psi (861 kPa)
- Maximum Hot Water Temperature 180°F (82°C)
- Temperature Adjustment Range 60 - 95°F (15 - 35°C)
- Factory Set Temperature* 85°F (29°C)
- Bypass Flow Rate at 30psid* 6.5 gpm (25 lpm)
- Maximum Flow with Cold Water Shutoff* 0.5 gpm (1.9 lpm)
- Listing ASSE 1071

* When tested under conditions specified in ASSE 1071 Standard

Capacity ■

| Flow Capacity at 85°F (29.4°C) | | | | | | | | | |
|--------------------------------|------------------------|----------------------------|---------------------|---------------------|---------------------|---------------------|---------------------|----------------------|----------------------|
| | | Pressure Drop Across Valve | | | | | | | |
| Model | Min. Flow to ASSE 1071 | C _v | 5psi (34 kPa) | 10psi (69 kPa) | 15psi (103 kPa) | 20psi (138 kPa) | 30psi (207 kPa) | 45psi (310 kPa) | 60psi (414 kPa) |
| ES150 | 1.0 gpm 3.8 lpm | 1.59 | 3.6 gpm 13.6 lpm | 5.0 gpm 18.9 lpm | 6.2 gpm 23.5 lpm | 7.1 gpm 26.9 lpm | 8.7 gpm 32.9 lpm | 10.7 gpm 40.5 lpm | 12.3 gpm 46.6 lpm |

Dimensions ■

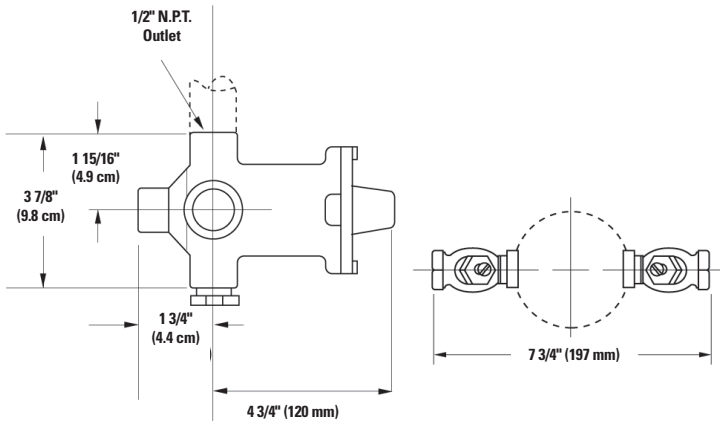

Ordering Information ■

E S 1 5 0

Order Code

Finish

Rough Bronze
Chrome Plated

1
2

Temperature/Pressure Gauge on Outlet

None
For rough bronze
For chrome plated

0
1
2

Recirculating Piping Diagram ■

Please see Piping Diagram Section of the Powers Full Line Catalog.

Typical Specification ■

Thermostatic mixing valve for supplying tepid water to emergency fixtures shall feature internal cold-water bypass system to ensure flow in the event of valve failure or loss of hot water supply. The valve shall be listed to ASSE 1071, provide precise temperature control over a wide range of flow conditions, and effectively shut down on loss of cold water. The valve shall feature powerful paraffin-based actuation technology and checkstops to prevent cross flow. The valve shall be factory set to 85°F (29°C) with a lockable mean of securing the temperature.

The valve shall be Powers' model ES150 _ _.

ENGINEERING APPROVAL

Project: _____
Contractor: _____
Architect/Engineer: _____

POWERS™

A Watts Water Technologies Company



ISO 9001-2000
CERTIFIED

USA: Phone: 1.800.669.5430 • Fax 1.847.229.0526 • www.powerscontrols.com
Canada: Phone: 1.888.208.8927 • Fax 1.888.479.2887 • www.powerscontrols.ca